

BALDOR® • RELIANCE 

Product Information Packet

JL3510A

1HP,1725RPM,1PH,60HZ,56J,3528L,TEFC,F1

Part Detail							
Revision:	Z	Status:	PRD/A	Change #:		Proprietary:	No
Type:	AC	Elec. Spec:	35WG0527	CD Diagram:	CD0094	Mfg Plant:	
Mech. Spec:	35F083	Layout:	35LYF083	Poles:	04	Created Date:	
Base:	N	Eff. Date:	03-08-2018	Leads:	4#18 A&J,1#14 #4TH		Y

Specs			
Catalog Number:	JL3510A	Inverter Code:	Not Inverter
Enclosure:	TEFC	KVA Code:	K
Frame:	56J	Lifting Lugs:	No Lifting Lugs
Frame Material:	Steel	Locked Bearing Indicator:	Locked Bearing
Output @ Frequency:	1.000 HP @ 60 HZ	Motor Lead Quantity/Wire Size:	4 @ 18 AWG, A&J
Synchronous Speed @ Frequency:	1800 RPM @ 60 HZ	Motor Lead Exit:	Ko Box
Voltage @ Frequency:	115.0 V @ 60 HZ	Motor Lead Termination:	Flying Leads
	230.0 V @ 60 HZ	Motor Type:	3528L
XP Class and Group:	None	Mounting Arrangement:	F1
XP Division:	Not Applicable	Power Factor:	68
Agency Approvals:	UR	Product Family:	General Purpose
	CSA	Pulley End Bearing Type:	Ball
Auxillary Box:	No Auxillary Box	Pulley Face Code:	C-Face
Auxillary Box Lead Termination:	None	Pulley Shaft Indicator:	Ext Thread
Base Indicator:	No Mounting	Rodent Screen:	None
Bearing Grease Type:	Polyrex EM (-20F +300F)	Shaft Extension Location:	Pulley End
Blower:	None	Shaft Ground Indicator:	No Shaft Grounding
Current @ Voltage:	12.400 A @ 115.0 V	Shaft Rotation:	Fixed Opposite Standard

	6.200 A @ 230.0 V	Shaft Slinger Indicator:	No Slinger
Design Code:	L	Speed Code:	Single Speed
Drip Cover:	No Drip Cover	Motor Standards:	NEMA
Duty Rating:	CONT	Starting Method:	Direct on line
Electrically Isolated Bearing:	Not Electrically Isolated	Thermal Device - Bearing:	None
Feedback Device:	NO FEEDBACK	Thermal Device - Winding:	Do Not Use Eve-Not Valid
Front Face Code:	Standard	Vibration Sensor Indicator:	No Vibration Sensor
Front Shaft Indicator:	None	Winding Thermal 1:	Automatic Thermal Overload
Heater Indicator:	No Heater	Winding Thermal 1 Location:	SB
Insulation Class:	F	Winding Thermal 2:	None

Nameplate NP1257L	
CAT.NO.	JL3510A
SPEC.	35F083-0527G1
HP	1
VOLTS	115/230
AMP	12.4/6.2
RPM	1725
FRAME	56J
SER.F.	1.00
NEMA-NOM-EFF	67
RATING	40C AMB-CONT
CC	
DE	6205
ENCL	TEFC
CODE	K
PF	68
HZ	60
DES	L
CL	F
PH	1
ODE	6203
SN	
USABLE AT 208V	

Parts List		
Part Number	Description	Quantity
SA024508	SA 35F083-0527G1	1.000 EA
RA020558	RA 35F083-0527G1	1.000 EA
TP5059	GENERIC THERMAL KIT	1.000 EA
EC1645A06SP	ELEC CAP, 645-774 MFD, 125V, 2.06D X 4.	1.000 EA
NS2512A01	INSULATOR, CONDUIT BOX X	1.000 EA
35CB3007	35 CB CASTING W/.88 DIA. LEAD HOLE	1.000 EA
36GS1000SP	GASKET-CONDUIT BOX, .06 THICK #SV-330 LE	1.000 EA
51XB1016A07	10-16 X 7/16 HXWSSLD SERTYB	2.000 EA
11XW1032G06	10-32 X .38, TAPTITE II, HEX WSHR SLTD U	1.000 EA
35EP3122K00	MASTER ODE,203 BRG,.683SH,#26 DRN,FH MTG	1.000 EA
51XW0832A07	8-32 X .44, TAPTITE II, HEX WSHR SLTD SE	2.000 EA
85XU0407S04	4X1/4 U DRIVE PIN STAINLESS	2.000 EA
51XB1016A05	10-16X5/16HX WA SL SR TYB (F/S)	2.000 EA
HW5100A03	WAVY WASHER (W1543-017)	1.000 EA
35EP3307G00	MASTER DE,205 BRG,1.232SH,#26 DRN	1.000 EA
51XN1032A20	10-32 X 1 1/4 HX WS SL SR	2.000 EA
35FN3002A05SP	EXFN, PLASTIC, 6.376 OD, .638 ID	1.000 EA
51XB1214A16	12-14X1.00 HXWSSLD SERTYB	1.000 EA
35FH4005A55	IEC FH NO GRSR,3 MTG HOLE NO DIMPLES,	1.000 EA
51XW1032A06	10-32 X .38, TAPTITE II, HEX WSHR SLTD S	3.000 EA
WD4100A10	465 NIAGARA PLUG (SO ELEC),FOR 1.093 DIA	1.000 EA
35CB4521GX	CONDUIT BOX LID KIT **ORDER INDIV PARTS	1.000 EA
51XW0832A07	8-32 X .44, TAPTITE II, HEX WSHR SLTD SE	4.000 EA
WD1000A15	3-520132-2 AMP FLAG (4M/RL NON-CANC/NON-	2.000 EA

Parts List (continued)		
Part Number	Description	Quantity
MJ1000A02	GREASE, MOBIL POLYREX EM - 124047	0.050 LB
MG1000G27	MED CHARCOAL METALLIC GREY 400-0096	0.017 GA
LB1009N	LABEL,ROTATION DIRECTION (ON ROLLS)	1.000 EA
SP5055A27	MODEL 35 TYPE L STATIONARY SWITCH LEAD A	1.000 EA
35CB4802A02SP	CAPACITOR COVER, STAMPED X	1.000 EA
35GS3001A02	GASKET, CA.COVER, 5.38 LONG .06 CS301	1.000 EA
HA3100A15	THRUBOLT 10-32 X 8.375	4.000 EA
LB1118	LABEL,WARNING (ROLL LABEL)	1.000 EA
LC0031	CONNECTION LABEL	1.000 EA
NP1257L	ALUM UL CSA CC THERMAL REV MTG	1.000 EA
PK3082	STYROFOAM CRADLE	1.000 EA
36PA1000	PKG GRP, PRINT PK1016A06	1.000 EA
MN416A01	TAG-INSTAL-MAINT no wire (1200/bx) 3/19	1.000 EA
PE-0000001	ZRTG PE ASSEMBLY	1.000 EA
FE-0000001	ZRTG FE ASSEMBLY	1.000 EA

AC Induction Motor Performance Data

Record # 61948 - Typical performance - not guaranteed values

Winding: 35WG0527-R003	Type: 3528L	Enclosure: OPEN
-------------------------------	--------------------	------------------------

Nameplate Data				115 V, 60 Hz: Low Voltage Connection	
Rated Output (HP)	1			Full Load Torque	3 LB-FT
Volts	115/230			Start Configuration	direct on line
Full Load Amps	12.4/6.2			Breakdown Torque	7 LB-FT
R.P.M.	1725			Pull-up Torque	3 LB-FT
Hz	60	Phase	1	Locked-rotor Torque	7.9 LB-FT
NEMA Design Code	L	KVA Code	K	Starting Current	78 A
Service Factor (S.F.)	1			No-load Current	7.6 A
NEMA Nom. Eff.	67	Power Factor	68	Line-line Res. @ 25°C	0.684 Ω A Ph 1.69 Ω B Ph
Rating - Duty	40C AMB-CONT			Temp. Rise @ Rated Load	42°C
				Locked-rotor Power Factor	93.3
				Rotor inertia	0.166 LB-FT ²

Load Characteristics 115 V, 60 Hz, 1 HP

% of Rated Load	25	50	75	100	125	150
Power Factor	41	57	70	76	83	86
Efficiency	51	64.5	67	68.5	66.5	63.5
Speed	1790	1780	1765	1750	1735	1710
Line amperes	8	9	10.4	12.4	14.5	17.4

Performance Graph at 115V, 60Hz, 1.0HP Typical performance - Not guaranteed values

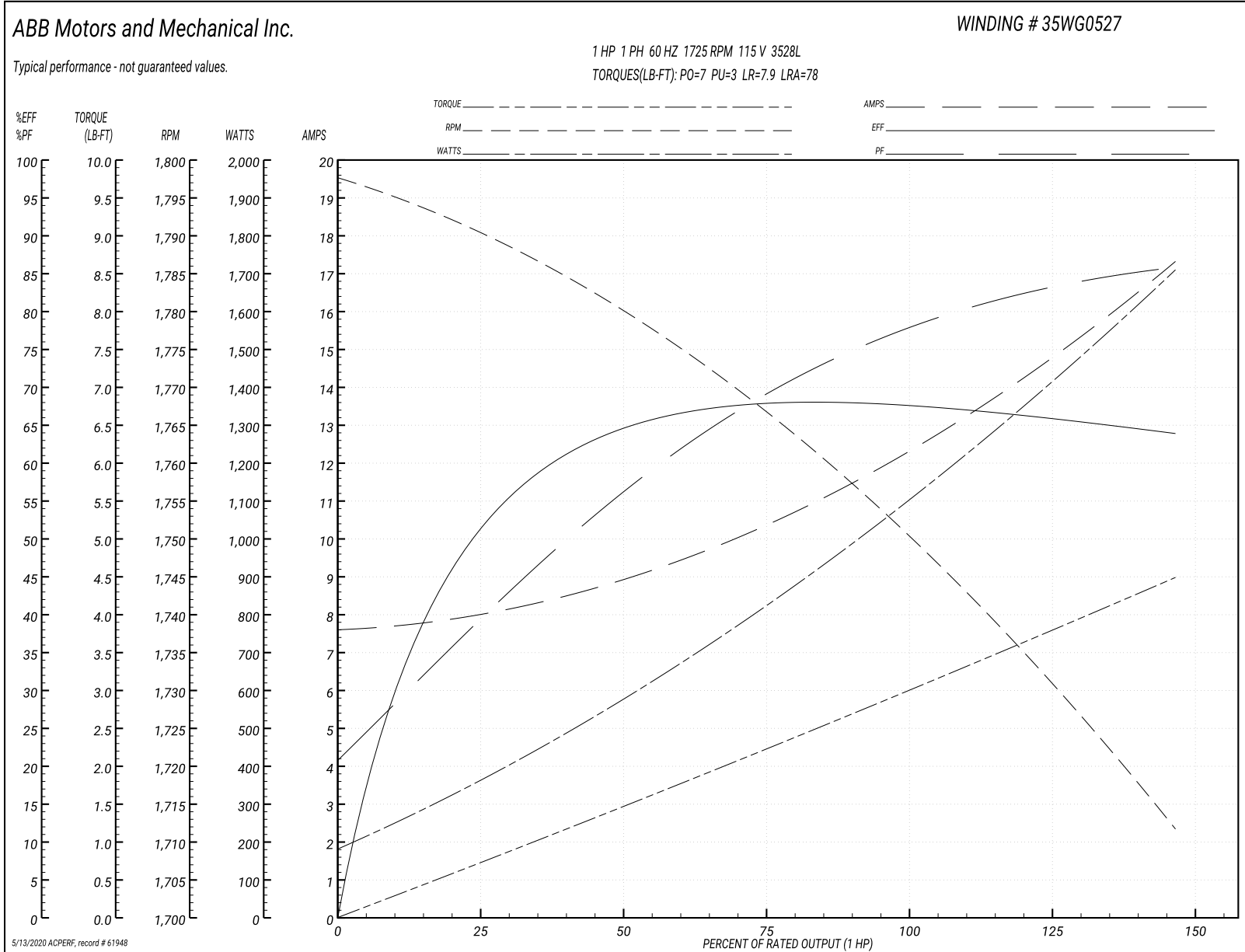

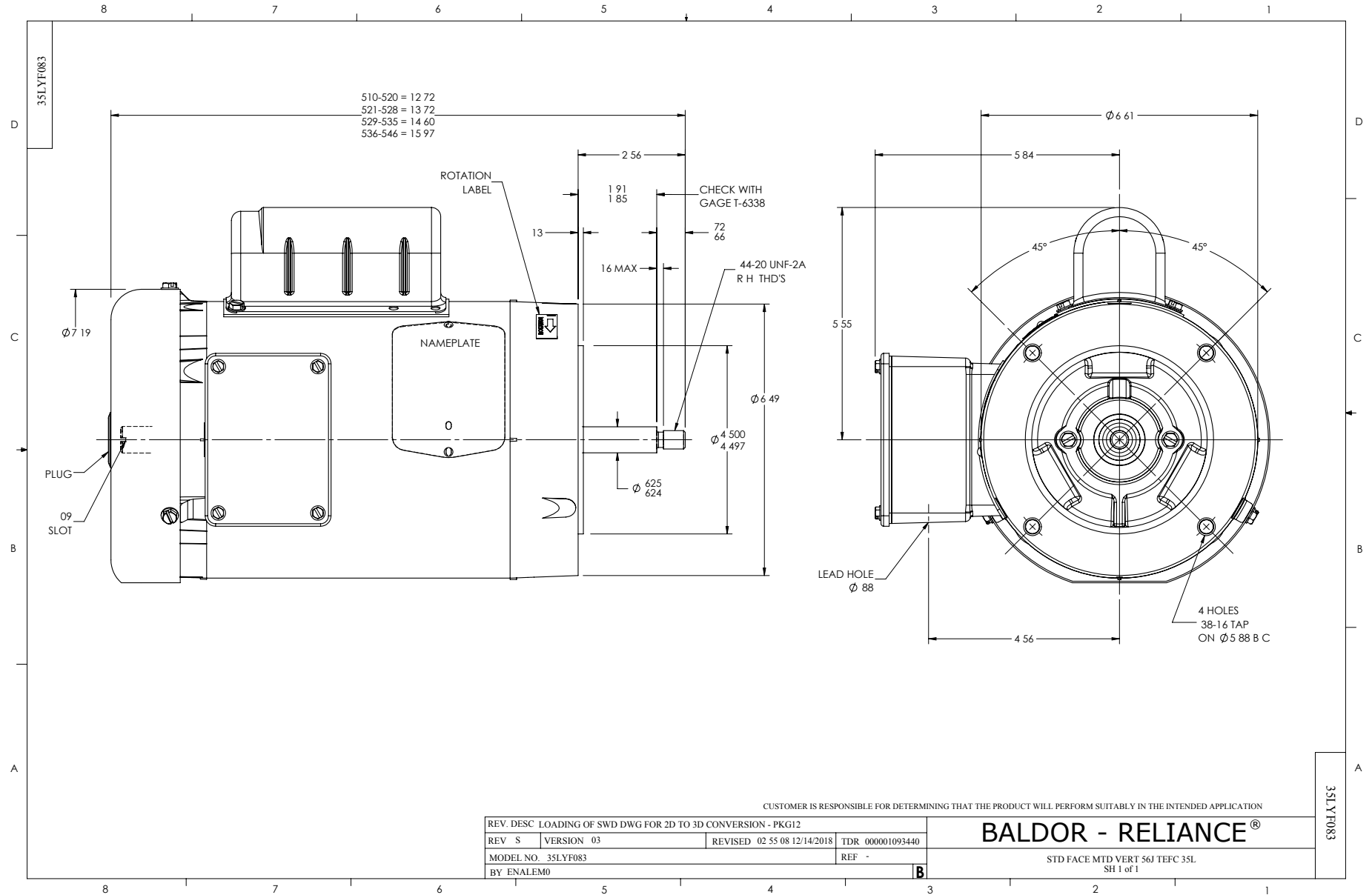

CD0094

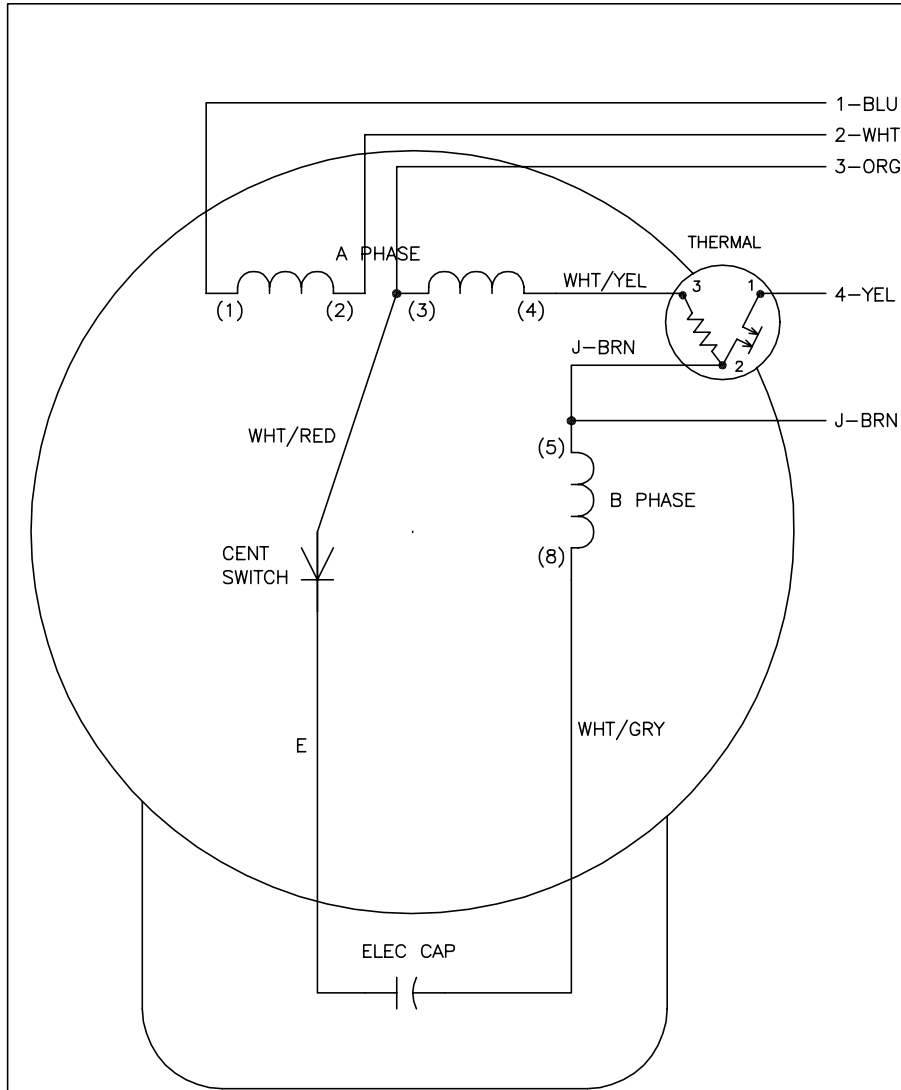

	LINE A	LINE B	JOIN	JOIN
HIGH	1	4	2,3	J
LOW	1,3	4	2,J	-

NOTES:

1. CONNECTIONS ARE SHOWN FOR CCW ROTATION FACING END OPPOSITE SHAFT EXTENSION (STD). FOR CW ROTATION, INTERCHANGE 5 AND 8 INTERNALLY.
2. MULTIPLE CAPACITORS ARE CONNECTED IN PARALLEL UNLESS OTHERWISE SPECIFIED.
3. LEAD COLORS ARE OPTIONAL. LEADS MUST ALWAYS BE NUMBERED AS SHOWN.

REV. DESC: REMOVE OPTIONAL THERMAL CONNECTION			
REV. LTR: E	VERSION: 01	TDR: 000000373039	
CD0094	FILE: \AAA\00007\476	REVISED: 11:12:36 08/11/2005	
	MTL: -	BY: ENJOEPO	

BALDOR ELECTRIC Co.

TYPE L, DV, FIX, THERMAL, 5 LEAD

CD0094